

15度曲げパイプ

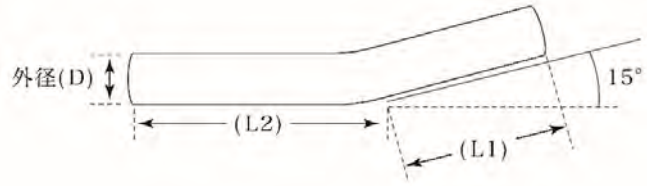

鉄製(メッキ管)

商品番号	外径(D)	内径(B)	全長(L1)	全長(L2)
CT-035	35.0	31.8	300	300
CT-038	38.1	34.9	300	300
CT-042	42.7	39.5	300	300
CT-048	48.6	45.4	300	300
CT-051	50.8	47.6	300	300
CT-054	54.0	50.8	300	300
CT-060	60.5	57.3	300	300
CT-065	65.0	61.8	300	300
CT-070	70.0	66.8	300	300
CT-075	75.0	71.8	300	300
CT-080	80.0	76.8	300	300
CT-089	89.1	85.9	300	300
CT-094	94.0	90.8	300	300
CT-101	101.6	98.4	300	300
CT-110	110.0	106.8	300	300

ステンレス製(SUS304・#400)

商品番号	外径(D)	内径(B)	全長(L1)	全長(L2)
CU-042	42.7	39.7	300	300
CU-050	50.0	47.0	300	300
CU-054	54.0	51.0	300	300
CU-060	60.5	57.5	300	300
CU-065	65.0	62.0	300	300
CU-070	70.0	67.0	300	300
CU-080	80.0	77.0	300	300
CU-101	101.6	98.6	300	300

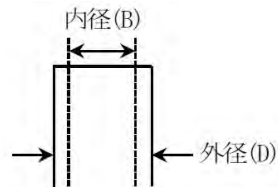

30度曲げパイプ

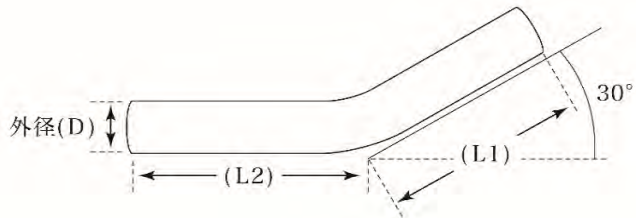

鉄製(メッキ管)

商品番号	外径(D)	内径(B)	全長(L1)	全長(L2)
21-032	31.8	28.6	300	300
21-035	35.0	31.8	300	300
21-038	38.1	34.9	300	300
21-042	42.7	39.5	300	300
21-048	48.6	45.4	300	300
21-051	50.8	47.6	300	300
21-054	54.0	50.8	300	300
21-060	60.5	57.3	300	300
21-065	65.0	61.8	300	300
21-070	70.0	66.8	300	300
21-075	75.0	71.8	300	300
21-080	80.0	76.8	300	300
21-089	89.1	85.9	300	300
21-094	94.0	90.8	300	300
21-101	101.6	98.4	300	300
21-110	110.0	106.8	300	300

ステンレス製(SUS304・#400)

商品番号	外径(D)	内径(B)	全長(L1)	全長(L2)
22-042	42.7	39.7	300	300
22-050	50.0	47.0	300	300
22-054	54.0	51.0	300	300
22-060	60.5	57.5	300	300
22-065	65.0	62.0	300	300
22-070	70.0	67.0	300	300
22-080	80.0	77.0	300	300
22-085	85.0	82.0	450	450
22-101	101.6	98.6	300	300

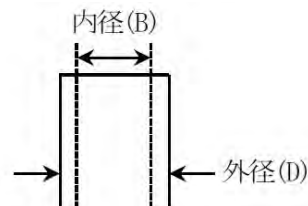

45度曲げパイプ Aタイプ

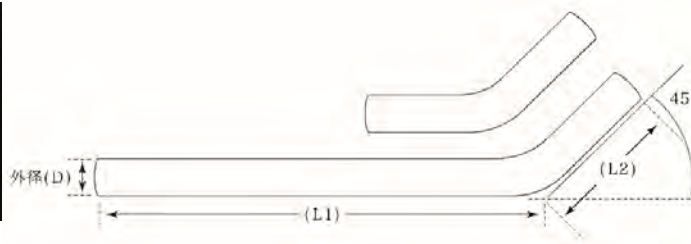

鉄製(メッキ管)

商品番号	外径(D)	内径(B)	全長(L1)	全長(L2)
23-032	31.8	28.6	300	300
23-035	35.0	31.8	300	300
23-038	38.1	34.9	300	300
23-042	42.7	39.5	300	300
23-048	48.6	45.4	300	300
23-051	50.8	47.6	300	300
23-L051	50.8	47.6	1000	300
23-054	54.0	50.8	300	300
23-060	60.5	57.3	300	300
23-L060	60.5	57.3	1000	300
23-065	65.0	61.8	300	300
23-L065	65.0	61.8	1000	300
23-070	70.0	66.8	300	300
23-L070	70.0	66.8	1000	300
23-075	75.0	71.8	300	300
23-L075	75.0	71.8	1000	300
23-080	80.0	76.8	300	300
23-L080	80.0	76.8	1000	300
23-089	89.1	85.9	300	300
23-L089	89.1	85.9	1000	300
23-094	94.0	90.8	300	300
23-L094	94.0	90.8	1000	300
23-101	101.6	98.4	300	300
23-L101	101.6	98.4	1000	300
23-110	110.0	106.8	300	300
23-L110	110.0	106.8	1000	300

ステンレス製(SUS304・#400)

商品番号	外径(D)	内径(B)	全長(L1)	全長(L2)
24-042	42.7	39.7	300	300
24-050	50.0	47.0	300	300
24-054	54.0	51.0	300	300
24-060	60.5	57.5	300	300
24-065	65.0	62.0	300	300
24-070	70.0	67.0	300	300
24-080	80.0	77.0	300	300
24-085	85.0	82.0	450	450
24-101	101.6	98.6	300	300

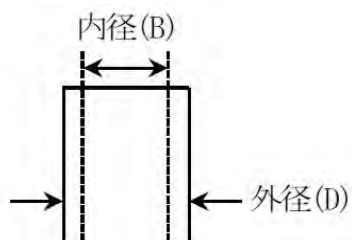

45度曲げパイプ Bタイプ

- ☆片側差し込みタイプ
- ☆クランプ付き(1個)

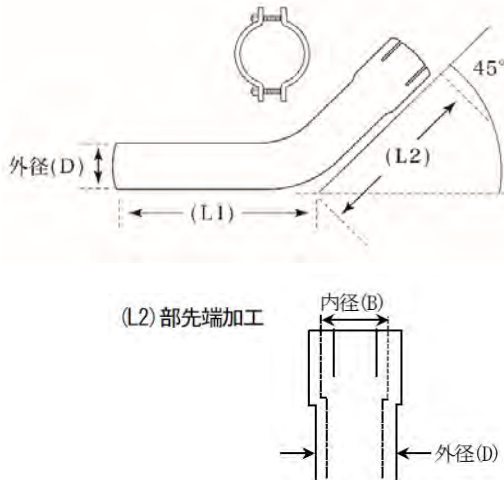

鉄製(メッキ管)

商品番号	外径(D)	内径(B)	全長(L1)	全長(L2)	付属クランプ
EP-035	35.0	36.0	300	200	95-038
EP-038	38.1	39.1	300	200	95-043
EP-042	42.7	43.7	300	200	95-048
EP-048	48.6	49.6	300	200	93-051
EP-051	50.8	51.8	300	200	95-054
EP-054	54.0	55.0	300	200	95-060
EP-060	60.5	61.5	300	200	91-060
EP-065	65.0	66.0	300	250	91-070
EP-070	70.0	71.0	300	250	91-070
EP-075	75.0	76.0	300	250	91-075
EP-080	80.0	81.0	300	250	91-H080
EP-094	94.0	95.0	300	250	91-094
EP-101	101.6	102.6	300	250	91-101
EP-110	110.0	111.0	300	300	91-109

ステンレス製(SUS304・#400)

商品番号	外径(D)	内径(B)	全長(L1)	全長(L2)	付属クランプ
EQ-042	42.7	43.7	300	200	95-048
EQ-050	50.0	51.8	300	200	95-054
EQ-054	54.0	55.0	300	200	95-060
EQ-060	60.5	61.5	300	200	91-060
EQ-065	65.0	66.0	300	250	91-070
EQ-070	70.0	71.0	300	250	91-070
EQ-075	75.0	76.0	300	250	91-075
EQ-080	80.0	81.0	300	250	91-H080

☆EQ系に付属するクランプは鉄製になります。

管継手(エルボ) 45度

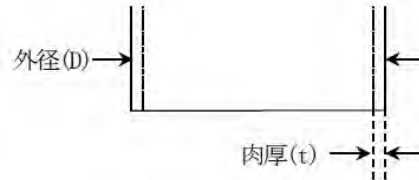

鉄製(SGP)

商品番号	外径(D)	肉厚(t)	寸法(L1)	寸法(L2)
07-L021	21.7	2.8	15.8	15.8
07-L027	27.2	2.8	15.8	15.8
07-L034	34.0	3.2	15.8	15.8
07-L042	42.7	3.5	19.7	19.7
07-048	48.6	3.5	15.8	15.8
07-L048	48.6	3.5	23.7	23.7
07-060	60.5	3.8	21.0	21.0
07-L060	60.5	3.8	31.6	31.6
07-076	76.3	4.2	26.3	26.3
07-L076	76.3	4.2	39.5	39.5
07-089	89.1	4.2	31.6	31.6
07-L089	89.1	4.2	47.3	47.3
07-101	101.6	4.2	36.8	36.8
07-L101	101.6	4.2	55.3	55.3
07-114	114.3	4.5	42.1	42.1
07-L114	114.3	4.5	63.1	63.1
07-139	139.8	4.5	52.6	52.6
07-L139	139.8	4.5	78.9	78.9
07-165	165.2	5.0	63.1	63.1
07-L165	165.2	5.0	94.7	94.7

ステンレス製(SUS304)

商品番号	外径(D)	肉厚(t)	寸法(L1)	寸法(L2)
AQ-L034	34.0	2.8	15.8	15.8
AQ-L042	42.7	2.8	19.7	19.7
AQ-L048	48.6	2.8	23.7	23.7
AQ-L060	60.5	2.8	31.6	31.6
AQ-L076	76.3	3.0	39.5	39.5
AQ-L089	89.1	3.0	47.3	47.3
AQ-L101	101.6	3.0	55.3	55.3
AQ-L114	114.3	3.0	63.1	63.1

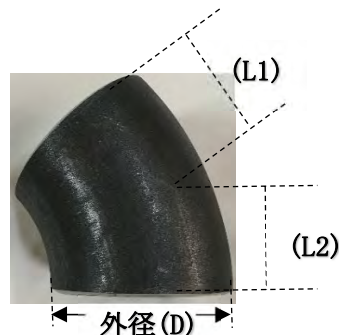

60度曲げパイプ Aタイプ

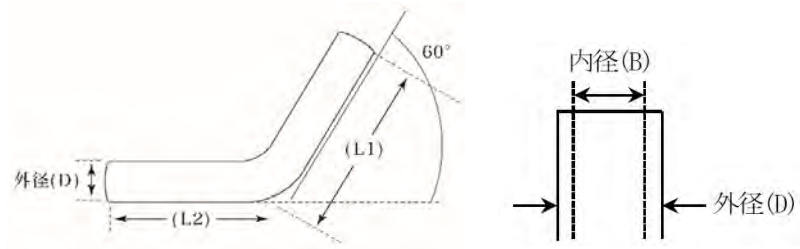

鉄製(メッキ管)

商品番号	外径(D)	内径(B)	全長(L1)	全長(L2)
25-032	31.8	28.6	300	300
25-035	35.0	31.8	300	300
25-038	38.1	34.9	300	300
25-042	42.7	39.5	300	300
25-048	48.6	45.4	300	300
25-051	50.8	47.6	300	300
25-L051	50.8	47.6	1000	300
25-054	54.0	50.8	300	300
25-060	60.5	57.3	300	300
25-L060	60.5	57.3	1000	300
25-065	65.0	61.8	300	300
25-L065	65.0	61.8	1000	300
25-070	70.0	66.8	300	300
25-075	75.0	71.8	300	300
25-L075	75.0	71.8	1200	250
25-080	80.0	76.8	300	300
25-L080	80.0	76.8	1200	250
25-089	89.1	85.9	300	300
25-L089	89.1	85.9	950	400
25-094	94.0	90.8	300	300
25-L094	94.0	90.8	1200	250
25-101	101.6	98.4	300	300
25-L101	101.6	98.4	1200	250
25-110	110.0	106.8	300	300
25-L110	110.0	106.8	1000	300

ステンレス製(SUS304・#400)

商品番号	外径(D)	内径(B)	全長(L1)	全長(L2)
26-042	42.7	39.7	300	300
26-050	50.0	47.0	300	300
26-L050	50.0	47.0	1000	300
26-054	54.0	51.0	300	300
26-L054	54.0	51.0	1000	300
26-060	60.5	57.5	300	300
26-L060	60.5	57.5	1000	300
26-065	65.0	62.0	300	300
26-L065	65.0	62.0	1000	300
26-070	70.0	67.0	300	300
26-080	80.0	77.0	300	300
26-L080	80.0	77.0	1200	250
26-085	85.0	82.0	450	450
26-101	101.6	98.6	300	300

60度曲げパイプ Bタイプ

- ☆片側差し込みタイプ
- ☆クランプ付き(1個)

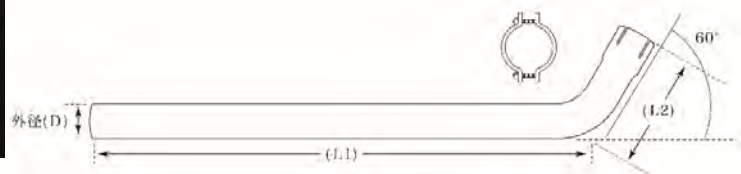
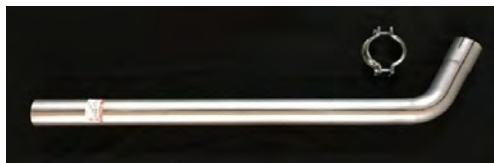

鉄製(メッキ管)

商品番号	外径(D)	内径(B)	全長(L1)	全長(L2)	付属クランプ
BL-L051	50.8	51.8	700	180	95-054
BL-L054	54.0	55.0	700	200	95-060
BL-L060	60.5	61.5	700	200	91-060
BL-T060	60.5	61.5	1000	200	91-060
BL-L065	65.0	66.0	1000	250	91-070
BL-L075	75.0	76.0	1200	250	91-075
BL-L080	80.0	81.0	1200	250	91-H080
BL-R080	80.0	85.0	1200	250	91-M089
BL-L094	94.0	95.0	1200	250	91-094
BL-L101	101.6	102.6	1200	250	91-101
BL-L110	110.0	111.0	1000	300	91-109

ステンレス製(SUS304・#400)

商品番号	外径(D)	内径(B)	全長(L1)	全長(L2)	付属クランプ
BN-L050	50.8	51.8	700	220	95-054
BN-L054	54.0	55.0	700	220	95-060
BN-L060	60.5	61.5	700	220	91-060
BN-T060	60.5	61.5	1000	220	91-060
BN-L065	65.0	66.0	1000	220	91-070
BN-L080	80.0	81.0	1200	250	91-H080
BN-L085	85.0	82.0	1200	250	91-H080

75度曲げパイプ

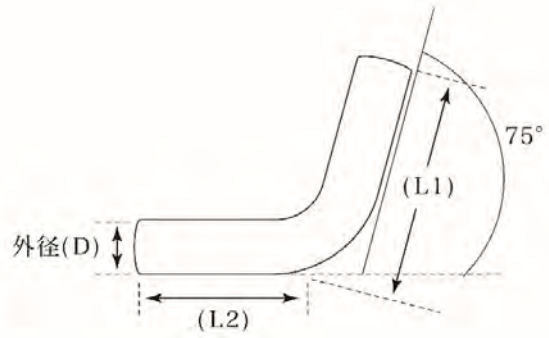

鉄製(メッキ管)

商品番号	外径(D)	内径(B)	全長(L1)	全長(L2)
CV-032	31.8	28.6	300	300
CV-035	35.0	31.8	300	300
CV-038	38.1	34.9	300	300
CV-042	42.7	39.5	300	300
CV-048	48.6	45.4	300	300
CV-051	50.8	47.6	300	300
CV-054	54.0	50.8	300	300
CV-060	60.5	57.3	300	300
CV-065	65.0	61.8	300	300
CV-070	70.0	66.8	300	300
CV-075	75.0	71.8	300	300
CV-080	80.0	76.8	300	300
CV-089	89.1	85.9	300	300
CV-094	94.0	90.8	300	300
CV-101	101.6	98.4	300	300
CV-110	110.0	106.8	350	350

ステンレス製(SUS304 #400)

商品番号	外径(D)	内径(B)	全長(L1)	全長(L2)
CW-042	42.7	39.7	300	300
CW-050	50.0	47.0	300	300
CW-054	54.0	51.0	300	300
CW-060	60.5	57.5	300	300
CW-065	65.0	62.0	300	300
CW-070	70.0	67.0	300	300
CW-080	80.0	77.0	300	300
CW-101	101.6	98.6	300	300

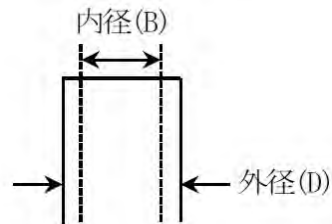

90度曲げパイプ Aタイプ

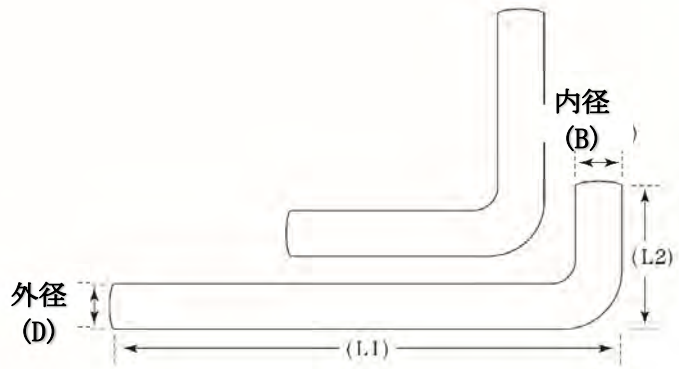

鉄製(メッキ管)

商品番号	外径(D)	内径(B)	全長(L1)	全長(L2)
11-032	31.8	28.6	300	300
11-035	35.0	31.8	300	300
11-038	38.1	34.9	300	300
11-042	42.7	39.5	300	300
11-L042	42.7	39.5	1000	300
11-048	48.6	45.4	300	300
11-051	50.8	47.6	300	300
11-L051	50.8	47.6	1000	500
11-054	54.0	50.8	300	300
11-L054	54.0	50.8	1000	300
11-060	60.5	57.3	600	400
11-L060	60.5	57.3	1000	500
11-065	65.0	61.8	300	300
11-L065	65.0	61.8	1000	300
11-070	70.0	66.8	500	500
11-L070	70.0	66.8	1000	290
11-075	75.0	71.8	650	550
11-T075	75.0	71.8	830	530
11-L075	75.0	71.8	1000	290
11-M075	75.0	71.8	1000	1000
11-R075	75.0	71.8	1600	650
11-V075	75.0	71.8	1680	1430
11-080	80.0	76.8	500	500
11-L080	80.0	76.8	1000	290
11-R080	80.0	76.8	2040	890
11-089	89.1	85.9	650	450
11-L089	89.1	85.9	1000	500
11-094	94.0	90.8	500	500
11-L094	94.0	90.8	1000	370
11-101	101.6	98.4	500	500
11-L101	101.6	98.4	1000	370
11-110	110.0	106.8	500	500
11-L110	110.0	106.8	1000	400
11-N114	110.0の曲げで両端を拡げ加工			
	114.3	111.1	385	385

ステンレス製(SUS304 #400)

商品番号	外径(D)	内径(B)	全長(L1)	全長(L2)
12-034	34.0	31.0	300	300
12-042	42.7	39.7	300	300
12-L042	42.7	39.7	1000	300
12-050	50.0	47.0	300	300
12-L050	50.0	47.0	1000	300
12-054	54.0	51.0	300	300
12-L054	54.0	51.0	1000	300
12-060	60.5	57.5	300	300
12-L060	60.5	57.5	700	290
12-065	65.0	62.0	300	300
12-L065	65.0	62.0	700	290
12-070	70.0	67.0	400	400
12-L070	70.0	67.0	1000	290
12-080	80.0	77.0	500	500
12-L080	80.0	77.0	1000	290
12-101	101.6	98.6	500	500
下記商品は溶接品となります。 (エルボ使用で2か所溶接)				
12-089W	89.1	86.1	500	500
12-114W	114.3	110.3	500	500

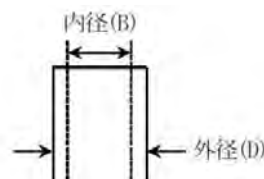
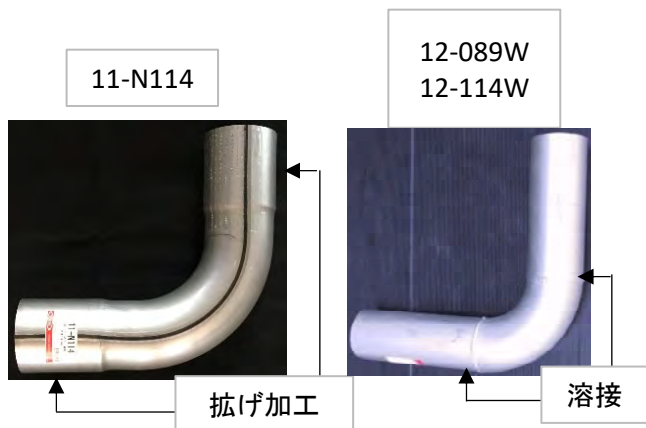

90度曲げパイプ Bタイプ

☆片側差し込みタイプ
☆クランプ付き(1個)

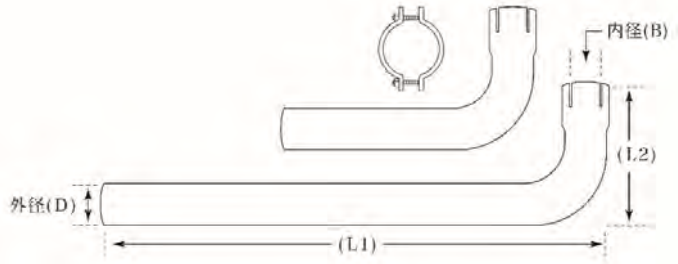

鉄製(メッキ管)

商品番号	外径 (D)	内径 (B)	全長 (L1)	全長 (L2)	付属クランプ
13-035	35.0	36.0	300	300	95-038
13-038	38.1	39.1	300	300	95-043
13-042	42.7	43.7	300	300	95-048
13-048	48.6	49.6	300	300	93-051
13-051	50.8	51.8	300	300	95-054
13-L051	50.8	51.8	700	180	95-054
13-054	54.0	55.0	300	300	95-060
13-L054	54.0	55.0	700	220	95-060
13-060	60.5	61.5	300	300	91-060
13-L060	60.5	61.5	700	250	91-060
13-065	65.0	66.0	300	300	91-070
13-L065	65.0	66.0	1000	300	91-070
13-070	70.0	71.0	500	290	91-070
13-L070	70.0	71.0	1000	290	91-070
13-075	75.0	76.0	500	290	91-075
13-L075	75.0	76.0	1000	290	91-075
13-080	80.0	81.0	500	290	91-H080
13-L080	80.0	81.0	1000	290	91-H080
13-R080	80.0	85.0	1000	290	91-M089
13-089	89.1	90.1	500	370	91-094
13-L089	89.1	90.1	1000	370	91-094
13-094	94.0	95.0	500	370	91-094
13-L094	94.0	95.0	1000	370	91-094
13-101	101.6	102.6	500	370	91-101
13-L101	101.6	102.6	1000	370	91-101
13-N101	101.6	111.0	1000	370	91-109
13-R101	101.6	98.4	1000	370	91-101
13-V101	101.6	107.0	1000	370	91-109
13-110	110.0	111.0	500	410	91-109
13-L110	110.0	111.0	1000	410	91-109
13-N110	110.0	115.3	1000	410	91-109

ステンレス製(SUS304 #400)

商品番号	外径 (D)	内径 (B)	全長 (L1)	全長 (L2)	付属クランプ
14-042	42.7	43.7	300	300	95-048
14-050	50.0	51.8	300	300	95-054
14-L050	50.0	51.8	700	220	95-054
14-054	54.0	55.0	300	300	95-060
14-L054	54.0	55.0	700	220	95-060
14-060	60.5	61.5	300	300	91-060
14-L060	60.5	61.5	700	220	91-060
14-T060	60.5	61.5	860	220	91-060
14-065	65.0	66.0	300	300	91-070
14-L065	65.0	66.0	700	290	91-070
14-070	70.0	71.0	400	400	91-070
14-L070	70.0	71.0	1000	290	91-070
14-080	80.0	81.0	500	500	91-H080
14-L080	80.0	81.0	1000	290	91-H080
14-101	101.6	102.6	500	370	91-101
下記商品は、溶接加工品となります。 (曲げ無しでカット製作品)					
14-N114W	114.3	110.3	1000	250	91-109

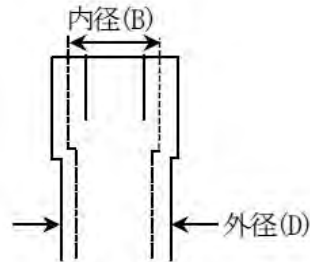

90度曲げパイプ Cタイプ

- ☆両側差し込みタイプ
- ☆クランプ付き(2個)

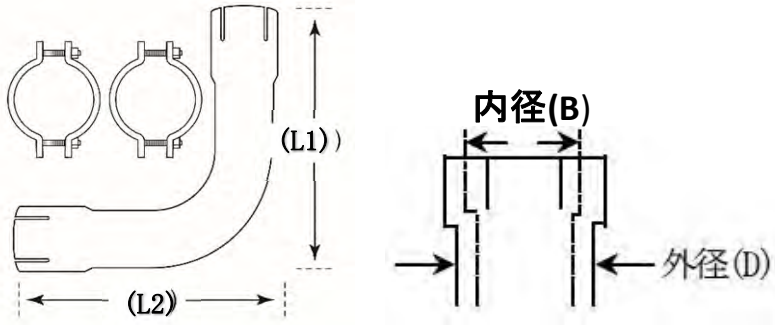

鉄製(メッキ管)

商品番号	外径 (D)	内径 (B)	全長 (L1)	全長 (L2)	付属クランプ
DA-035	35.0	36.0	300	300	95-038
DA-038	38.1	39.1	300	300	95-043
DA-042	42.7	43.7	300	300	95-048
DA-048	48.6	49.6	300	300	93-051
DA-051	50.8	51.8	300	300	95-054
DA-054	54.0	55.0	340	340	95-060
DA-060	60.5	61.5	300	300	91-060
DA-065	65.0	66.0	400	400	91-070
DA-070	70.0	71.0	390	390	91-070
DA-075	75.0	76.0	370	370	91-075
DA-080	80.0	81.0	350	350	91-H080
DA-089	89.1	90.1	520	520	91-094
DA-094	94.0	95.0	400	400	91-094
DA-101	101.6	102.6	420	420	91-101
DA-110	110.0	111.0	410	410	91-109

ステンレス製(SUS304・#400)

商品番号	外径 (D)	内径 (B)	全長 (L1)	全長 (L2)	付属クランプ
DD-042	42.7	43.7	300	300	95-048
DD-050	50.0	51.8	300	300	95-054
DD-054	54.0	55.0	300	300	95-060
DD-060	60.5	61.5	360	360	91-060
DD-065	65.0	66.0	300	300	91-070
DD-070	70.0	71.0	390	390	91-070
DD-080	80.0	81.0	300	300	91-H080
DD-101	101.6	102.6	420	420	91-101

☆ステンレス製(DD系)に付属するクランプは鉄製になります。

90度曲げパイプ Fタイプ

- ☆片側ラップ加工タイプ
- ☆クランプ別売り

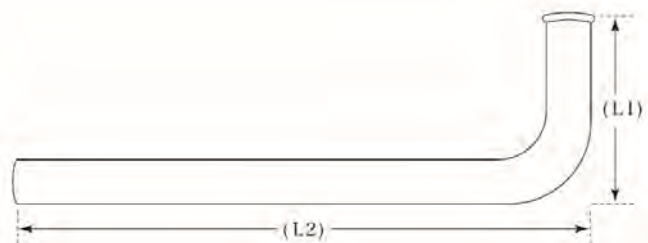

鉄製(メッキ管)

商品番号	外径 (D1)	肉厚 (t)	外径 (D2)	全長 (L1)	全長 (L2)	別売クランプ
FB-075	75.0	1.6	90.0	350	1000	DY-07690
FB-094	94.0	1.6	106.0	370	1000	DY-094106
FB-110	110.0	1.6	120.0	460	1000	DY-113120

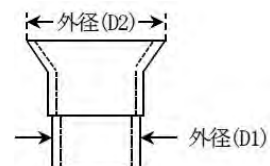

管継手(エルボ) 90度



鉄製 (SGP)

商品番号	外径(D)	肉厚(t)	寸法(L1)	寸法(L2)
08-L021	21.7	2.8	38.1	38.1
08-L027	27.2	2.8	38.1	38.1
08-034	34.0	3.2	25.4	25.4
08-L034	34.0	3.2	38.1	38.1
08-042	42.7	3.5	31.8	31.8
08-L042	42.7	3.5	47.6	47.6
08-048	48.6	3.5	38.1	38.1
08-L048	48.6	3.5	57.2	57.2
08-060	60.5	3.8	50.8	50.8
08-L060	60.5	3.8	76.2	76.2
08-076	76.3	4.2	63.5	63.5
08-L076	76.3	4.2	95.3	95.3
08-089	89.1	4.2	76.2	76.2
08-L089	89.1	4.2	114.3	114.3
08-101	101.6	4.2	88.9	88.9
08-L101	101.6	4.2	133.4	133.4
08-114	114.3	4.5	101.6	101.6
08-L114	114.3	4.5	152.4	152.4
08-139	139.8	4.5	127.0	127.0
08-L139	139.8	4.5	190.5	190.5
08-165	165.2	5.0	152.4	152.4
08-L165	165.2	5.0	228.6	228.6

ステンレス製 (SUS304)

商品番号	外径(D)	肉厚(t)	寸法(L1)	寸法(L2)
AR-034	34.0	2.8	25.4	25.4
AR-L034	34.0	2.8	38.1	38.1
AR-042	42.7	2.8	31.8	31.8
AR-L042	42.7	2.8	47.6	47.6
AR-048	48.6	2.8	38.1	38.1
AR-L048	48.6	2.8	57.2	57.2
AR-060	60.5	2.8	50.8	50.8
AR-L060	60.5	2.8	76.2	76.2
AR-076	76.3	3.0	63.5	63.5
AR-L076	76.3	3.0	95.3	95.3
AR-089	89.1	3.0	76.2	76.2
AR-L089	89.1	3.0	114.3	114.3
AR-101	101.6	3.0	88.9	88.9
AR-L101	101.6	3.0	133.4	133.4
AR-114	114.3	3.0	101.6	101.6
AR-L114	114.3	3.0	152.4	152.4

管継手(エルボ) 90度

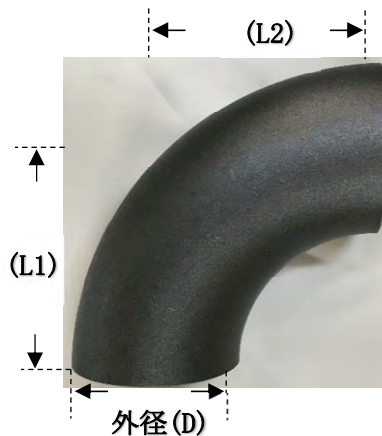

ステンレス製 (SUS304・#600 研磨仕上げ)

商品番号	外径(D)	肉厚(t)	寸法(L1)	寸法(L2)
10-076	76.3	2.0	95.3	95.3
10-089	89.1	2.0	114.3	114.3
10-101	101.6	2.0	133.4	133.4
10-114	114.3	2.0	152.4	152.4
10-139	139.8	3.0	190.5	190.5

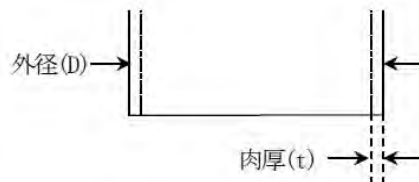

120度曲げパイプ

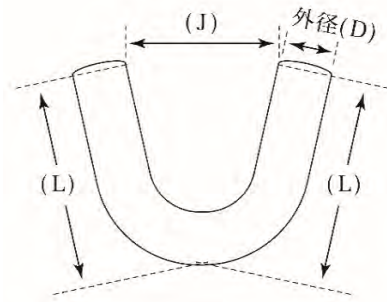

鉄製(メッキ管)

商品番号	外径(D)	内径(B)	内寸(J)	全長(L)
27-035	35.0	31.8	385	300
27-038	38.1	34.9	370	300
27-042	42.7	39.5	355	300
27-045	45.0	41.8	360	300
27-048	48.6	45.4	365	300
27-051	50.8	47.6	380	300
27-054	54.0	50.8	350	300
27-060	60.5	57.3	335	300
27-065	65.0	61.8	300	300
27-070	70.0	66.8	385	300
27-075	75.0	71.8	365	300
27-080	80.0	76.8	340	300
27-089	89.1	85.9	470	300
27-094	94.0	90.8	360	300
27-101	101.6	98.4	370	300
27-110	110.0	106.8	380	300

ステンレス製(SUS304)

商品番号	外径(D)	内径(B)	内寸(J)	全長(L)
28-042	42.7	39.7	350	300
28-050	50.0	47.0	345	300
28-054	54.0	51.0	350	300
28-060	60.5	57.5	335	300
28-065	65.0	62.0	300	300
28-070	70.0	67.0	385	300
28-075	75.0	72.0	365	300
28-080	80.0	77.0	340	300

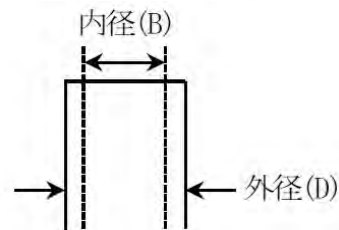

150度曲げパイプ

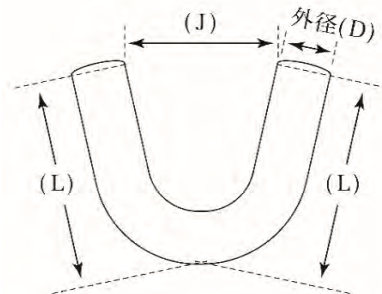

鉄製(メッキ管)

商品番号	外径(D)	内径(B)	内寸(J)	全長(L)
CX-035	35.0	31.8	250	300
CX-038	38.1	34.9	265	300
CX-042	42.7	39.5	255	300
CX-045	45.0	41.8	270	300
CX-048	48.6	45.4	265	300
CX-051	50.8	47.6	300	300
CX-054	54.0	50.8	225	300
CX-060	60.5	57.3	275	300
CX-065	65.0	61.8	220	300
CX-070	70.0	66.8	290	300
CX-075	75.0	71.8	285	300
CX-080	80.0	76.8	250	300
CX-089	89.1	85.9	405	300
CX-094	94.0	90.8	270	300
CX-101	101.6	98.4	300	300
CX-110	110.0	106.8	300	300

ステンレス製(SUS304)

商品番号	外径(D)	内径(B)	内寸(J)	全長(L)
CY-042	42.7	39.7	260	300
CY-050	50.0	47.0	265	300
CY-054	54.0	51.0	225	300
CY-060	60.5	57.5	275	300
CY-065	65.0	62.0	220	300
CY-070	70.0	67.0	290	300
CY-075	75.0	72.0	285	300
CY-080	80.0	77.0	250	300

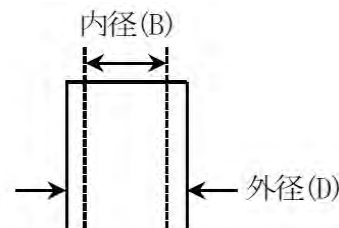

U型曲げパイプ(Aタイプ)

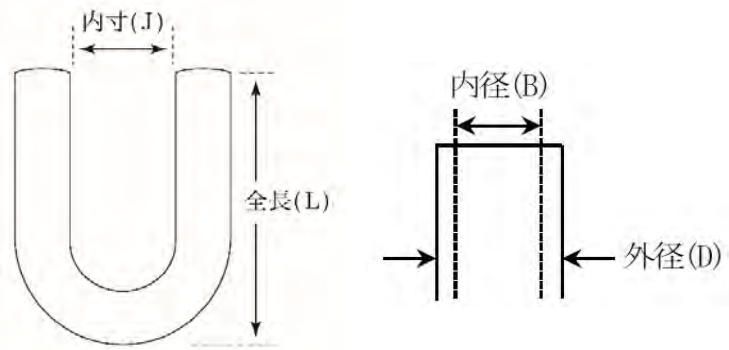

鉄製(メッキ管)

商品番号	外径(D)	内径(B)	内寸(J)	全長(L)
15-042	42.7	39.5	140	400
15-051	50.8	47.6	150	400
15-060	60.5	57.3	200	400
15-065	65.0	61.8	115	280
15-075	75.0	71.8	185	400
15-080	80.0	76.8	160	400
15-089	89.1	85.9	310	400
15-094	94.0	90.8	185	400
15-101	101.6	98.4	200	400
15-110	110.0	106.8	210	410

ステンレス製(SUS304)

商品番号	外径(D)	内径(B)	内寸(J)	全長(L)
16-042	42.7	39.7	140	300
16-050	50.0	47.0	150	300
16-054	54.0	51.0	110	300
16-060	60.5	57.5	200	300
16-065	65.0	62.0	115	300
16-080	80.0	77.0	165	300

U型曲げパイプ(Bタイプ)

- ☆片側差し込みタイプ
- ☆クランプ付き(1個)

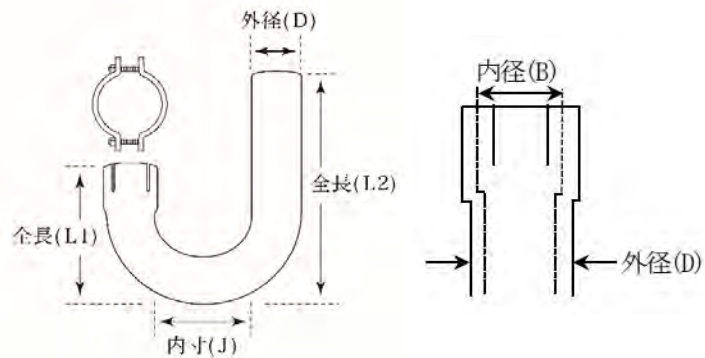

鉄製(メッキ管)

商品番号	外径(D)	内径(B)	全長(L1)	全長(L2)	内寸(J)	付属クランプ
AU-051	50.8	51.8	180	300	150	95-054
AU-060	60.5	61.5	230	300	200	91-060
AU-075	75.0	76.0	240	370	185	91-075
AU-080	80.0	81.0	230	360	160	91-H080
AU-094	94.0	95.0	250	380	186	91-094
AU-101	101.6	102.6	260	390	200	91-101
AU-110	110.0	111.0	410	550	210	91-109

継手管(エルボ) 180度

鉄製(SGP)

商品番号	外径(D)	肉厚(t)	寸法(L1)	寸法(L2)
09-L021	21.7	2.8	76.2	49.0
09-L027	27.2	2.8	76.2	51.7
09-034	34.0	3.2	50.8	42.4
09-L034	34.0	3.2	76.2	55.1
09-042	42.7	3.5	63.6	53.2
09-L042	42.7	3.5	95.2	69.0
09-048	48.6	3.5	76.2	62.4
09-L048	48.6	3.5	114.4	81.5
09-060	60.5	3.8	101.6	81.1
09-L060	60.5	3.8	152.4	106.5
09-076	76.3	4.2	127.0	101.7
09-L076	76.3	4.2	190.6	133.5
09-089	89.1	4.2	152.4	120.8
09-L089	89.1	4.2	228.8	158.9
09-101	101.6	4.2	177.8	139.7
09-L101	101.6	4.2	266.8	184.2
09-114	114.3	4.5	203.2	158.8
09-L114	114.3	4.5	304.8	209.6

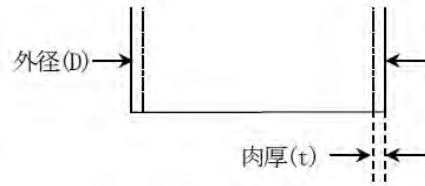
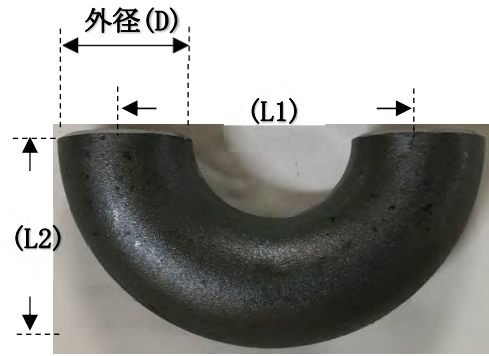

ステンレス製(SUS304)

商品番号	外径(D)	肉厚(t)	寸法(L1)	寸法(L2)
BU-L042	42.7	2.8	95.2	69.0
BU-L048	48.6	2.8	114.4	81.5
BU-L060	60.5	2.8	152.4	106.5
BU-L076	76.3	3.0	190.6	133.5
BU-L089	89.1	3.0	228.6	158.9
BU-L114	114.3	3.0	304.8	209.6



J型曲げパイプ

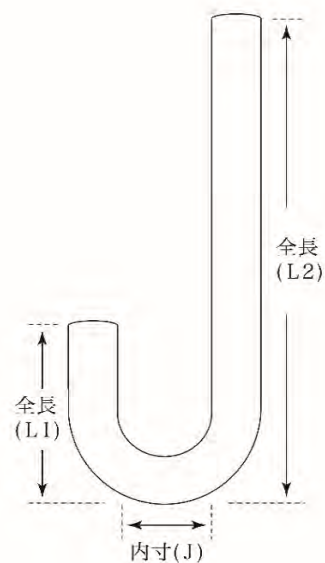
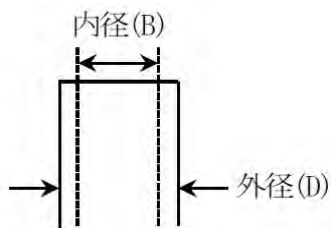

鉄製(メッキ管)

商品番号	外径(D)	内径(B)	内寸(J)	全長(L1)	全長(L2)
BM-051	50.8	47.6	150	300	800
BM-060	60.5	57.3	200	300	800
BM-075	75.0	71.8	185	300	800
BM-080	80.0	76.8	160	300	800
BM-094	94.0	90.8	185	300	800
BM-101	101.6	98.4	200	300	800
BM-110	110.0	106.8	210	410	800

クランク型曲げパイプ(Aタイプ)

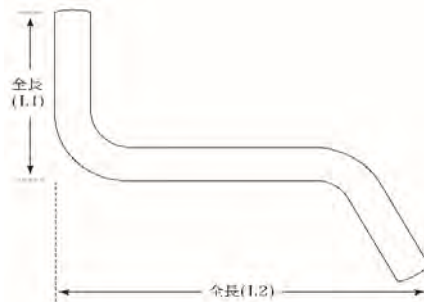

鉄製(メッキ管)

商品番号	外径(D)	内径(B)	全長(L1)	全長(L2)	外径(D2)
31-035	35.0	31.8	300	600	
31-038	38.1	34.9	300	600	
31-042	42.7	39.5	300	600	
31-048	48.6	45.4	300	600	
31-051	50.8	47.6	300	600	
31-054	54.0	50.8	300	600	
31-060	60.5	57.3	300	800	
31-065	65.0	61.8	300	780	
31-070	70.0	66.8	400	800	
31-075	75.0	71.8	400	800	
31-080	80.0	76.8	450	800	
31-089	89.1	85.9	450	900	
31-094	94.0	90.8	370	830	
31-101	101.6	98.4	400	870	
31-N101	101.6	106.8	400	870	110.0
31-110	110.0	106.8	490	840	

ステンレス製(SUS304 #400)

商品番号	外径(D)	内径(B)	全長(L1)	全長(L2)
30-042	42.7	39.7	300	600
30-050	50.0	47.0	300	600
30-054	54.0	51.0	300	600
30-060	60.5	57.5	300	800
30-065	65.0	62.0	300	800
30-070	70.0	67.0	400	800
30-075	75.0	72.0	400	800
30-080	80.0	77.0	450	800
30-101	101.6	98.6	400	870

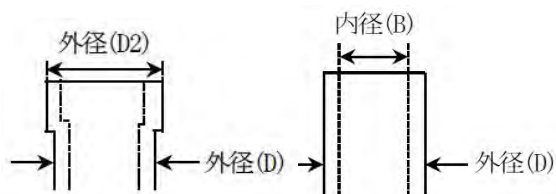

クランク型曲げパイプ(Bタイプ)

- ☆片側差し込みタイプ
- ☆クランプ付き(1個)

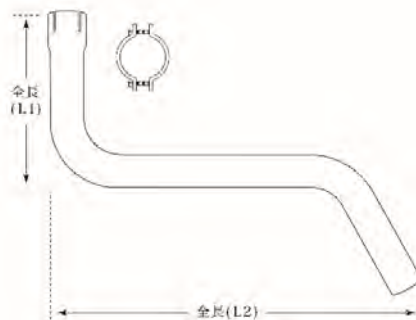

鉄製(メッキ管)

商品番号	外径(D)	内径(B)	全長(L1)	全長(L2)	付属クランプ
33-035	35.0	36.0	300	600	95-038
33-038	38.1	39.1	300	600	95-043
33-042	42.7	43.7	300	600	95-048
33-048	48.6	49.6	300	600	93-051
33-051	50.8	51.8	300	600	95-054
33-054	54.0	55.0	300	600	95-060
33-060	60.5	61.5	500	850	91-060
33-065	65.0	66.0	300	780	91-070
33-070	70.0	71.0	400	800	91-070
33-075	75.0	76.0	500	850	91-075
33-080	80.0	81.0	450	800	91-H080
33-089	89.1	90.1	500	650	91-094
33-094	94.0	95.0	370	830	91-094
33-101	101.6	102.6	400	870	91-101
33-N101	101.6	111.0	400	870	91-109
33-110	110.0	111.0	490	840	91-109

ステンレス製(SUS304・#400)

商品番号	外径(D)	内径(B)	全長(L1)	全長(L2)	付属クランプ
32-042	42.7	43.7	300	600	95-048
32-050	50.0	51.8	300	600	95-054
32-054	54.0	55.0	300	600	95-060
32-060	60.5	61.5	300	800	91-060
32-065	65.0	66.0	300	800	91-070
32-070	70.0	71.0	400	800	91-070
32-080	80.0	81.0	450	800	91-H080
32-101	101.6	102.6	400	870	91-101

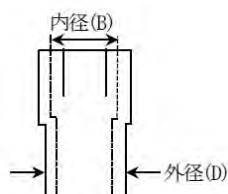

クランク型曲げパイプ(Fタイプ)

☆片側ラッパ加工タイプ
☆クランプ別売り

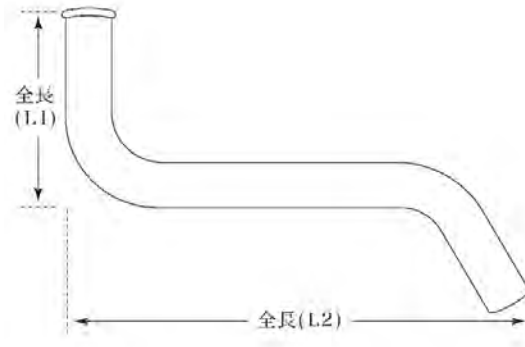

鉄製(メッキ管)

商品番号	外径(D1)	外径(D2)	全長(L1)	全長(L2)	クランプ
FC-075	75.0	90.0	350	800	DY-07690
FC-094	94.0	106.0	300	830	DY-094106
FC-110	110.0	120.0	490	840	DY-113120

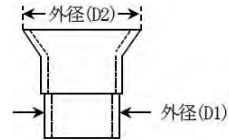

S型曲げパイプ(Aタイプ)

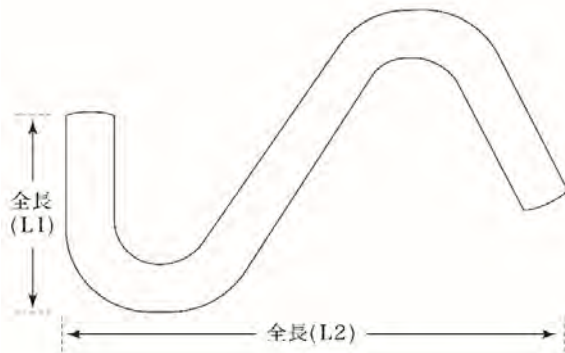

鉄製(メッキ管)

商品番号	外径(D)	内径(B)	全長(L1)	全長(L2)	外径(D2)
35-035	35.0	31.8	300	700	
35-038	38.1	34.9	300	700	
35-042	42.7	39.5	300	700	
35-048	48.6	45.4	300	700	
35-051	50.8	47.6	300	700	
35-054	54.0	50.8	300	700	
35-060	60.5	57.3	350	900	
35-065	65.0	61.8	400	900	
35-070	70.0	66.8	400	850	
35-075	75.0	71.8	350	850	
35-080	80.0	76.8	350	950	
35-089	89.1	85.9	350	1000	
35-094	94.0	90.8	300	830	
35-101	101.6	98.4	370	920	
35-N101	101.6	106.8	370	920	110.0
35-110	110.0	106.8	420	840	

ステンレス製(SUS304 #400)

商品番号	外径(D)	内径(B)	全長(L1)	全長(L2)
34-042	42.7	39.7	300	700
34-050	50.0	47.0	300	700
34-054	54.0	51.0	350	700
34-060	60.5	57.5	350	900
34-065	65.0	62.0	350	900
34-070	70.0	67.0	400	850
34-075	75.0	72.0	350	850
34-080	80.0	77.0	350	800

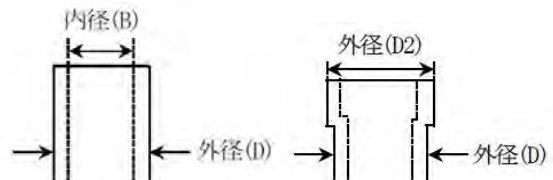

S型曲げパイプ(Bタイプ)

☆片側差し込みタイプ
☆クランプ付き(1個)

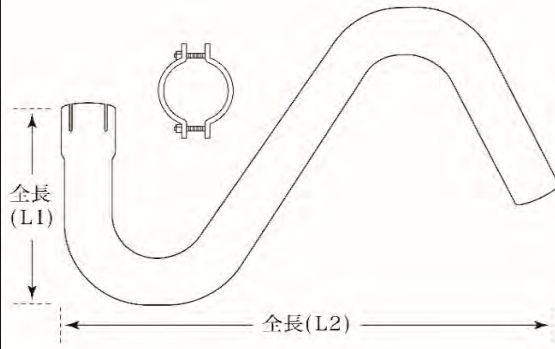

鉄製(メッキ管)

商品番号	外径(D)	内径(B)	全長(L1)	全長(L2)	付属クランプ
37-035	35.0	36.0	300	700	95-038
37-038	38.1	39.1	300	700	95-043
37-042	42.7	43.7	300	700	95-048
37-048	48.6	49.6	300	700	93-051
37-051	50.8	51.8	300	700	95-054
37-054	54.0	55.0	300	700	95-060
37-060	60.5	61.5	350	900	91-060
37-065	65.0	66.0	400	900	91-070
37-070	70.0	71.0	400	850	91-070
37-075	75.0	76.0	350	850	91-075
37-080	80.0	81.0	350	950	91-H080
37-R080	80.0	85.0	400	820	91-M089
37-089	89.1	90.1	350	1000	91-094
37-094	94.0	95.0	300	830	91-094
37-101	101.6	102.6	370	920	91-101
37-N101	101.6	111.0	370	920	91-109
37-110	110.0	111.0	420	840	91-109

ステンレス製(SUS304・#400)

商品番号	外径(D)	内径(B)	全長(L1)	全長(L2)	付属クランプ
36-042	42.7	43.7	300	700	95-048
36-050	50.0	51.8	300	700	95-054
36-054	54.0	55.0	350	700	95-060
36-060	60.5	61.5	350	900	91-060
36-065	65.0	66.0	350	900	91-070
36-070	70.0	71.0	400	850	91-070
36-080	80.0	81.0	350	800	91-H080

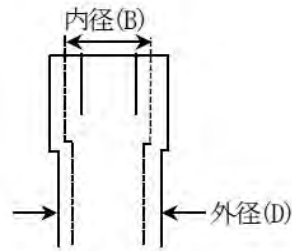

S型曲げパイプ(Fタイプ)

☆片側ラツパ加工タイプ
☆クランプ別売り

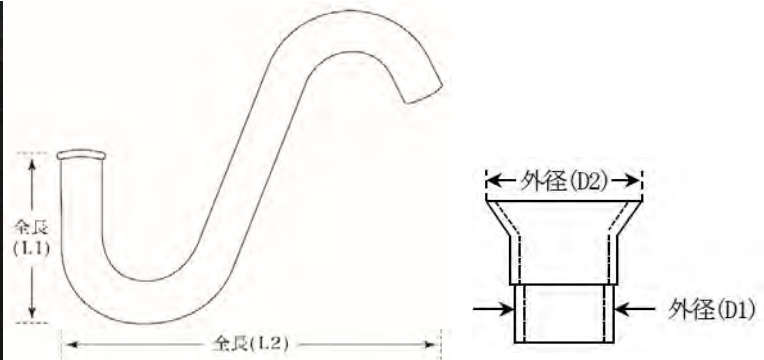

鉄製(メッキ管)

商品番号	外径(D1)	肉厚(t)	外径(D2)	全長(L1)	全長(L2)	別売クランプ
FD-075	75.0	1.6	90.0	300	820	DY-07690
FD-094	94.0	1.6	106.0	370	830	DY-094106
FD-110	110.0	1.6	120.0	420	840	DY-113120

ブリッジ型曲げパイプ

☆プロペラシャフト越えやデフ越え等の迂回などに使用できます。

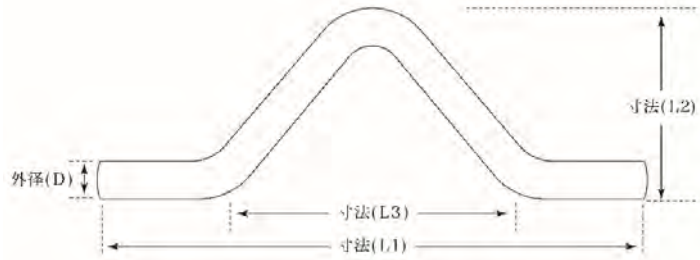

鉄製(メッキ管)

商品番号	外径(D)	内径(B)	全長(L1)	寸法(L2)	寸法(L3)
DU-051	50.8	47.6	800	300	450
DU-054	54.0	50.8	800	300	450
DU-060	60.5	57.3	800	300	450
DU-065	65.0	61.8	800	300	450

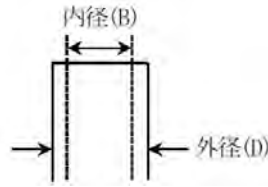

ステアー型曲げパイプ

☆曲げ2か所は45度曲げ。

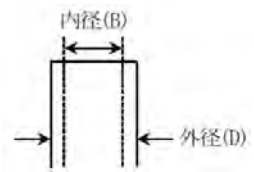
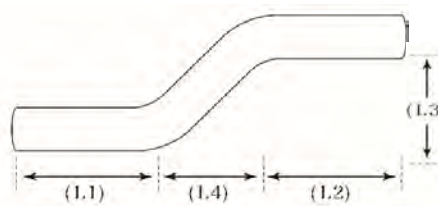

鉄製(メッキ管)

商品番号	外径(D)	内径(B)	寸法(L1)	寸法(L2)	寸法(L3)	寸法(L4)
EJ-051	50.8	47.6	200	200	130	130
EJ-060	60.5	57.3	200	200	136	136

まんじ型曲げパイプ

☆曲げ2か所は90度曲げ。

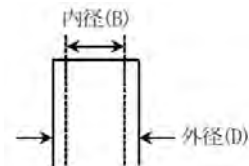
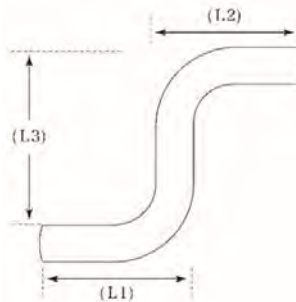

鉄製(メッキ管)

商品番号	外径(D)	内径(B)	寸法(L1)	寸法(L2)	寸法(L3)
EH-051	50.8	47.6	200	200	300
EH-060	60.5	57.3	210	210	310

サイドガード コーナーパイプ

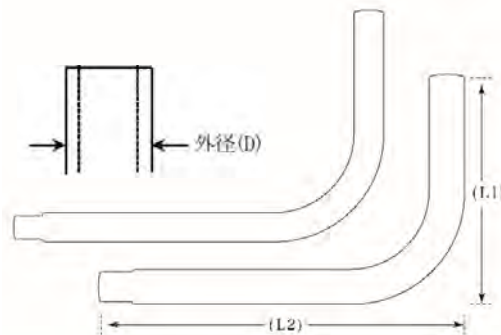

鉄製(メッキ管)

商品番号	外径(D)	肉厚(t)	全長(L1)	全長(L2)
29-027	27.2	2.3	210	290
29-034	34.0	2.3	210	290

ステンレス製(SUS304 #400)

商品番号	外径(D)	肉厚(t)	全長(L1)	全長(L2)
29-S027	27.2	2.0	210	290
29-S034	34.0	2.0	210	290